



HARDWARE INSTALLATION GUIDE

cnPilot Enterprise Wi-Fi Access Points

System Release 4.2.3



Reservation of Rights

Cambium reserves the right to make changes to any products described herein to improve reliability, function, or design, and reserves the right to revise this document and to make changes from time to time in content hereof with no obligation to notify any person of revisions or changes. Cambium recommends reviewing the Cambium Networks website for the latest changes and updates to products. Cambium does not assume any liability arising out of the application or use of any product, software, or circuit described herein; neither does it convey license under its patent rights or the rights of others. It is possible that this publication may contain references to, or information about Cambium products (machines and programs), programming, or services that are not announced in your country. Such references or information must not be construed to mean that Cambium intends to announce such Cambium products, programming, or services in your country.

Copyrights

This document, Cambium products, and 3rd Party software products described in this document may include or describe copyrighted Cambium and other 3rd Party supplied computer programs stored in semiconductor memories or other media. Laws in the United States and other countries preserve for Cambium, its licensors, and other 3rd Party supplied software certain exclusive rights for copyrighted material, including the exclusive right to copy, reproduce in any form, distribute and make derivative works of the copyrighted material. Accordingly, any copyrighted material of Cambium, its licensors, or the 3rd Party software supplied material contained in the Cambium products described in this document may not be copied, reproduced, reverse engineered, distributed, merged or modified in any manner without the express written permission of Cambium. Furthermore, the purchase of Cambium products shall not be deemed to grant either directly or by implication, estoppel, or otherwise, any license under the copyrights, patents or patent applications of Cambium or other 3rd Party supplied software, except for the normal non-exclusive, royalty free license to use that arises by operation of law in the sale of a product.

Restrictions

Software and documentation are copyrighted materials. Making unauthorized copies is prohibited by law. No part of the software or documentation may be reproduced, transmitted, transcribed, stored in a retrieval system, or translated into any language or computer language, in any form or by any means, without prior written permission of Cambium.

License Agreements

The software described in this document is the property of Cambium and its licensors. It is furnished by express license agreement only and may be used only in accordance with the terms of such an agreement.

High Risk Materials

Cambium and its supplier(s) specifically disclaim any express or implied warranty of fitness for any high-risk activities or uses of its products including, but not limited to, the operation of nuclear facilities, aircraft navigation or aircraft communication systems, air traffic control, life support, or weapons systems ("High Risk Use").

This product is not restricted in the EU. Any High Risk is unauthorized, is made at your own risk and you shall be responsible for any and all losses, damage or claims arising out of any High-Risk Use.

Contents

- Contents** **3**
- Chapter 1: About This User Guide** **6**
 - Overview of cnPilot products 6
 - Intended audience 6
 - Purpose 6
 - Related documents 7
 - New Platforms 7
 - Reporting problems, security advice and safety and regulatory information 7
 - Reporting problems 7
 - Security advice 8
 - Safety and regulatory information 8
 - Important safety information 8
 - Power lines 8
 - Working at heights 8
 - Grounding and protective earth 8
 - Powering down before servicing 9
 - Primary disconnect device 9
 - RF exposure near the antenna 9
 - Important regulatory information 9
 - Radar avoidance 9
 - USA and Canada specific information 9
 - FCC radiation exposure statement 10
 - IC statement 10
 - IC radiation exposure statement 11
 - CE statement 11
 - Human exposure to radio frequency energy 11
 - Specific expertise and training required for professional installers 11
 - Avoidance of weather radars 12

Ethernet networking skills	12
Lightning protection and grounding guidelines	12
Lightning protection guidelines	12
Grounding guidelines	14
Pole or tower mount guidelines	15
Wall mount guidelines	16
Training	17
Power density exposure limit	17
Calculation of power density and distance	18
Calculated distances and power compliance margins	19
Chapter 2: Packaging and Installation of cnPilot Enterprise Wi-Fi Access Point	21
Unpacking cnPilot Enterprise Wi-Fi Access Point	21
Package contents	21
Mounting the device	21
Mounting e400/e410/e600	23
Ceiling mount	23
Wall Mounting	23
T-Bar Mounting	25
24mm T-Bar	26
14mm T-Bar	27
Mounting e410b	28
Ceiling Mount:	28
Wall Mounting:	29
T-bar Mounting	29
Mounting e500	31
Pole mount	31
Wall Mounting (w/o bracket)	32
Wall Mounting (with bracket)	33
Mounting e501S/e502S	35
Pole mount	35

Wall Mounting	36
Mounting e700	37
Pole mount	37
Wall Mounting	39
Mounting e430/e425H	40
Single Gang Mounting	40
Dual Gang Mounting	42
Wall Mounting	44
Mounting e505/e510	45
Pole Mount	45
Wall Mounting	45

Chapter 1: About This User Guide

This chapter describes the following topics:

- Overview of cnPilot products
- Intended audience
- Purpose
- Related documents
- New hardware platforms
- Reporting problems, security advice and safety and regulatory information
- USA and Canada specific information
- Specific expertise and training required for professional installers
- Avoidance of weather radars
- Ethernet networking skills
- Lightning protection and grounding guidelines
- Pole or tower mount guidelines
- Wall mount guidelines
- Training
- Power density exposure limit

Overview of cnPilot products

Thank you for choosing Cambium cnPilot Enterprise Wi-Fi Access Point (AP)!

This User Guide describes the features supported by cnPilot Enterprise Wi-Fi AP and provides detailed instructions for setting Up and configuring cnPilot Enterprise AP.

cnPilot's are the industry's upcoming feature-rich Wi-Fi APs designed for Indoor/Outdoor which are easy to deploy and configure.

Intended audience

This guide is intended for use by the system designer, system installer and system administrator.

Purpose

Cambium Networks cnPilot Enterprise Wi-Fi AP documents are intended to instruct and assist personnel in the operation, installation and maintenance of the Cambium's equipment and ancillary devices. It is recommended that all personnel engaged in such activities be properly trained.

Cambium Networks disclaims all liability whatsoever, implied or expressed, for any risk of damage, loss or reduction in system performance arising directly or indirectly out of the failure of the customer, or anyone acting on the customer's behalf, to abide by the instructions, system parameters, or recommendations made in this document.

Related documents

Table 1 Related documents provides details on cnPilot's Enterprise Wi-Fi Access Point support information.

Table 1 Related documents

cnPilot Enterprise Wi-Fi product details	https://www.cambiumnetworks.com/products/wifi/
cnPilot Enterprise Wi-Fi AP User Guide (This document)	https://support.cambiumnetworks.com/files
cnPilot Enterprise Wi-Fi AP Release Notes	https://support.cambiumnetworks.com/files
Software Resources	https://support.cambiumnetworks.com/files
Knowledge Base (KB) Articles	http://community.cambiumnetworks.com/t5/cnPilot-E-Series-Enterprise-APs/bd-p/cnPilot_E_Series/
Community	http://community.cambiumnetworks.com/
Support	https://www.cambiumnetworks.com/support/contact-support/
Warranty	https://www.cambiumnetworks.com/support/warranty/
Feedback	For feedback, e-mail to support@cambiumnetworks.com

New Platforms

System Release 4.2 includes the following new Platforms:

Table 1: New platforms

Hardware	Description
e410b	2x2:2, 802.11a/b/g/n/ac wave 2 Indoor Access Point.

Reporting problems, security advice and safety and regulatory information

This section includes the following topics:

- Reporting problems
- Security advice
- Safety and regulatory information

Reporting problems

If any problems are encountered when installing or operating this equipment, follow this procedure to investigate and report:

1. Search this document and the software release notes of supported releases.
2. Visit the Support website: <http://www.cambiumnetworks.com/support>

3. Ask for assistance from the Cambium product supplier.
4. Gather information from affected units, such as any available diagnostic downloads.
5. Escalate the problem by emailing or telephoning support:
<https://www.cambiumnetworks.com/support/contact-support/>

Security advice

Cambium Network's systems and equipment provide security parameters that can be configured by the operator based on their particular operating environment. Cambium Network's recommends setting and using these parameters following industry recognized security practices. Security aspects to be considered are protecting the confidentiality, integrity, and availability of information and assets. Assets include the ability to communicate, information about the nature of the communications, and information about the parties involved.

In certain instances, Cambium makes specific recommendations regarding security practices, however the implementation of these recommendations and final responsibility for the security of the system lies with the operator of the system.

Cambium Network's cnPilot Enterprise Wi-Fi AP equipment is shipped with default web management interface login credentials. It is highly recommended that the following default username and password should be modified prior to system installation.

Username: admin

Password: admin

Safety and regulatory information

This section describes important safety and regulatory guidelines that must be observed by personnel installing or operating cnPilot Enterprise Access Point equipment.

Important safety information



Warning

To prevent loss of life or physical injury, observe the safety guidelines in this section.

Power lines

Exercise extreme care when working near power lines.

Working at heights

Exercise extreme care when working at heights.

Grounding and protective earth

cnPilot Enterprise Access Point (AP) devices must be properly grounded to protect against lightning. It is the responsibility of the user to install the equipment in accordance with national regulations. In the USA, follow Section 810 of the National Electric Code, ANSI/NFPA No.70-1984 (USA). In Canada, follow Section 54 of the Canadian Electrical Code. These codes describe correct installation procedures for grounding the outdoor unit, mast, lead-in wire and discharge unit, size of grounding conductors and connection requirements for grounding electrodes. Other regulations may apply in different countries and therefore it is recommended that installation be contracted to a professional installer.

Powering down before servicing

Always power down and unplug the equipment before servicing.

Primary disconnect device

The cnPilot Enterprise AP power supply is the primary disconnect device.

RF exposure near the antenna

Strong Radio Frequency (RF) fields will be present close to the antenna when the transmitter is ON. Always turn OFF the power to the cnPilot AP device before undertaking maintenance activities in front of the antenna.

Important regulatory information

The cnPilot Enterprise AP product is certified as an unlicensed device in frequency bands where it is not allowed to cause interference to licensed services (called primary users of the bands).

Radar avoidance

In countries where radar systems are the primary band users, the regulators have mandated special requirements to protect these systems from interference caused by unlicensed devices. Unlicensed devices must detect and avoid co-channel operation with radar systems.

The cnPilot Enterprise AP detects and avoids functionality for countries and frequency bands requiring protection for radar systems. The cnPilot Enterprise AP is qualified for ETSI/FCC DFS certification (see Note) for radar detection and avoidance as per the law.



Note

Country-specific limits apply, some bands require DFS. DFS bands operation subject to regulatory approval. Check Software release notes for details.

Installers and users must meet all local regulatory requirements for radar detection. To meet these requirements, users must set the correct country code during commissioning of the cnPilot Enterprise AP equipment. If this is not done, installers and users may be liable to civil and criminal penalties.

Contact the Cambium helpdesk if more guidance is required.

USA and Canada specific information

Federal Communication Commission interference statement

This equipment has been tested and found to comply with the limits for a Class B digital device, pursuant to Part 15 of the FCC Rules. These limits are designed to provide reasonable protection against harmful interference in a residential installation. This equipment generates, uses and can radiate radio frequency energy and, if not installed and used in accordance with the instructions, may cause harmful interference to radio communications. However, there is no guarantee that interference will not occur in a particular installation. If this equipment does cause harmful interference to radio or television reception, which can be determined by turning the equipment off and on, the user is encouraged to try to correct the interference by one of the following measures:

- Reorient or relocate the receiving antenna.
- Increase the separation between the equipment and receiver.

- Connect the equipment into an outlet on a circuit different from that to which the receiver connected.
- Consult the dealer or an experienced radio/TV technician for help.



Attention

Any changes or modifications not expressly approved by the party responsible for compliance could void the user's authority to operate this equipment.

This device complies with Part 15 of the FCC Rules. Operation is subject to the following two conditions: (1) This device may not cause harmful interference, and (2) this device must accept any interference received, including interference that may cause undesired operation.

For product available in the USA/Canada market, only channel 1-11 can be operated. Selection of other channels is not possible.

This device and its antennas(s) must not be co-located or operating in conjunction with any other antenna or transmitter except in accordance with FCC multi-transmitter product procedures.

This device is restricted for indoor use.

FCC radiation exposure statement

This equipment complies with FCC radiation exposure limits set forth for an uncontrolled environment. This equipment should be installed and operated with minimum distance 20 cm between the radiator and your body.

IC statement

This device complies with Industry Canada license-exempt RSS standard(s). Operation is subject to the following two conditions: (1) this device may not cause interference, and (2) this device must accept any interference, including interference that may cause undesired operation of the device.

Le présent appareil est conforme aux CNR d'Industrie Canada applicables aux appareils radio exempts de licence. L'exploitation est autorisée aux deux conditions suivantes (1) l'appareil ne doit pas produire de brouillage, et (2) l'utilisateur de l'appareil doit accepter tout brouillage radioélectrique subi, même si le brouillage est susceptible d'en compromettre le fonctionnement.

For product available in the USA/Canada market, only channel 1-11 can be operated. Selection of other channels is not possible.

Pour les produits disponibles aux États-Unis / Canada du marché, seul le canal 1 à 11 peuvent être exploités. Sélection d'autres canaux n'est pas possible.

This device and its antennas(s) must not be co-located or operating in conjunction with any other antenna or transmitter except in accordance with IC multi-transmitter product procedures.

Cet appareil et son antenne (s) ne doit pas être co-localisés ou fonctionnement en association avec une autre antenne ou transmetteur.

The device for the band 5150-5250 MHz is only for indoor usage to reduce potential for harmful interference to co-channel mobile satellite systems.

les dispositifs fonctionnant dans la bande 5150-5250 MHz sont réservés uniquement pour une utilisation à l'intérieur afin de réduire les risques de brouillage préjudiciable aux systèmes de satellites mobiles utilisant les mêmes canaux;

IC radiation exposure statement

This equipment complies with IC RSS-102 radiation exposure limits set forth for an uncontrolled environment. This equipment should be installed and operated with minimum distance 20 cm between the radiator and your body.

Cet équipement est conforme aux limites d'exposition aux rayonnements IC établies pour un environnement non contrôlé. Cet équipement doit être installé et utilisé avec un minimum de 20 cm de distance entre la source de rayonnement et votre corps.

CE statement

This equipment complies with EU radiation exposure limits set forth for an uncontrolled environment. This equipment should be installed and operated with minimum distance 20 cm between the radiator and your body.

Human exposure to radio frequency energy

Relevant standards (USA and EC) applicable when working with RF equipment are:

- ANSI IEEE C95.1-1991, IEEE Standard for Safety Levels with Respect to Human Exposure to Radio Frequency Electromagnetic Fields, 3 kHz to 300 GHz.
- Council recommendation of 12 July 1999 on the limitation of exposure of the general public to electromagnetic fields (0 Hz to 300 GHz) (1999/519/EC) and respective national regulations.
- Directive 2004/40/EC of the European Parliament and of the Council of 29 April 2004 on the minimum health and safety requirements regarding the exposure of workers to the risks arising from physical agents (electromagnetic fields) (18th individual Directive within the meaning of Article 16(1) of Directive 89/391/EEC).
- US FCC limits for the general population. See the FCC website at <https://www.fcc.gov/>, and the policies, guidelines, and requirements in Part 1 of Title 47 of the Code of Federal Regulations, as well as the guidelines and suggestions for evaluating compliance in FCC OET Bulletin 65.
- Health Canada limits for the general population. See the Health Canada website at http://www.hc-sc.gc.ca/ewh-semt/pubs/radiation/radio_guide-lignes_direct/index-eng.php and Safety Code 6.
- EN 50383:2002 to 2010 Basic standard for the calculation and measurement of electromagnetic field strength and SAR related to human exposure from radio base stations and fixed terminal stations for wireless telecommunication systems (110 MHz - 40 GHz).
- BS EN 50385:2002 Product standard to demonstrate the compliances of radio base stations and fixed terminal stations for wireless telecommunication systems with the basic restrictions or the reference levels related to human exposure to radio frequency electromagnetic fields (110 MHz - 40 GHz) - general public.

ICNIRP (International Commission on Non-Ionizing Radiation Protection) guidelines for the general public. See the ICNIRP website at <http://www.icnirp.de/> and Guidelines for Limiting Exposure to Time-Varying Electric, Magnetic, and Electromagnetic Fields.

Specific expertise and training required for professional installers

To ensure that the cnPilot Enterprise Wi-Fi AP is installed and configured in compliance with the requirements of Industry Canada and the FCC, installers must have the radio engineering skills and training described in this section. This is particularly important when installing and configuring an cnPilot

Enterprise AP system for operation in the 5 GHz band (5150 – 5250 MHz – FCC only, 5250 – 5350 MHz, 5470 – 5725 MHz and 5725 – 5850 MHz).

Avoidance of weather radars

The installer must be familiar with the requirements in FCC KDB 443999. Essentially, the installer must be able to:

- Access the FCC database of weather radar location and channel frequencies.
- Use this information to correctly configure the product (using the UI) to avoid operation on channels that must be avoided according to the guidelines that are contained in the KDB and explained in detail in this user guide.
- In ETSI regions, the band 5600 MHz to 5650 MHz is reserved for the use of weather radars.

Ethernet networking skills

The installer must have the ability to configure IP addressing on a PC and to set up and control products using a web browser interface.

Lightning protection and grounding guidelines

This section includes the following topics:

- Lightning protection guidelines
- Grounding guidelines

Lightning protection guidelines

To protect outdoor radio installations from the impact of lightning strikes, the installer must be familiar with the normal procedures for site selection, bonding and grounding.



Warning

Electro-Magnetic Discharge (EMD) lightning damage is not covered under warranty. The recommendations in this section, when followed correctly, provides the user the best protection from the harmful effects of EMD. However, 100% protection is neither implied nor possible.

Purpose

To protect structures, equipment and people against power surges (typically caused by lightning) by conducting the surge current to ground via a separate preferential solid path. The actual degree of protection required depends on local conditions and applicable local regulations. Cambium Network's recommends cnPilot installation is contracted to a professional installer.

Standards

Refer international standards IEC 62305-1 and IEC 62304-4, the U.S. National Electric Code ANSI/NFPA No. 70-2017 or section 54 of the Canadian Electric Code for details of lightning protection methods and requirements.

Lightning protection installation zones

The “Rolling sphere method” is used to determine the safe zone to install the lightning protection equipment. An imaginary sphere, typically 50 meters in radius is rolled over the structure. Where the sphere rests against the ground and a strike termination device (such as a finial or ground bar), all the space under the sphere is in the zone of protection (Zone B) as shown in [Figure 1](#). Similarly, where the sphere rests on two finials, the space under the sphere is considered as in the zone of protection.

Figure 1: Rolling sphere method to determine the lightning protection zones

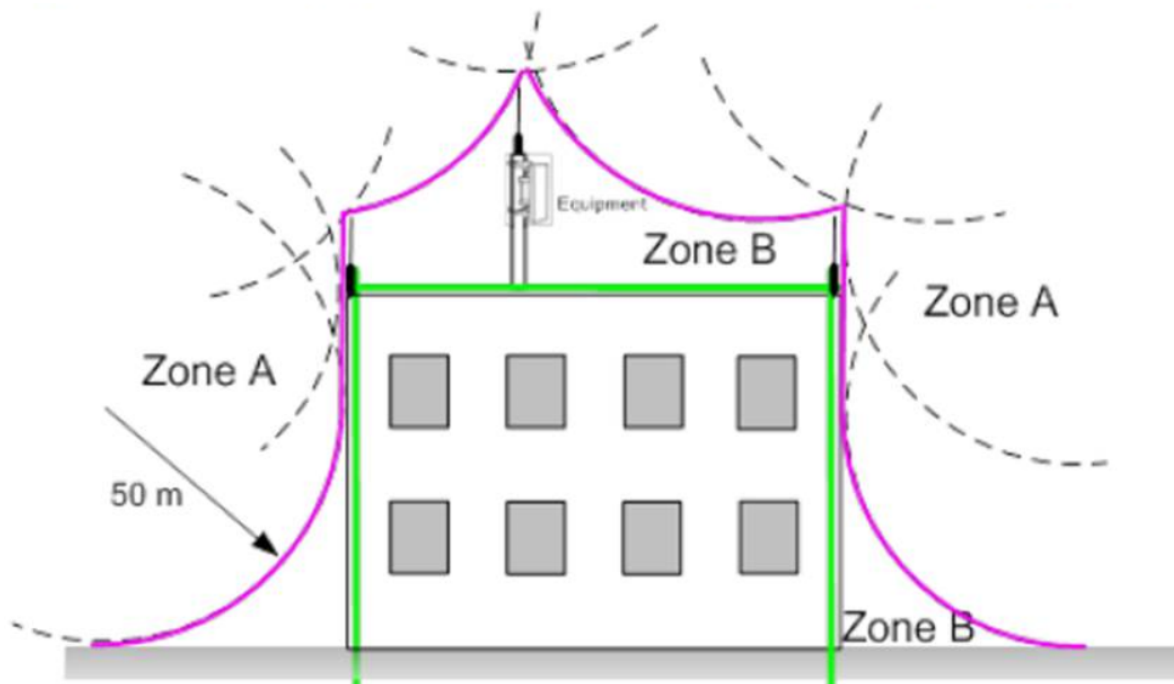

Assess locations on poles, towers and buildings to determine, whether the location is in Zone A or Zone B:

Zone A: In this zone a direct lightning strike is possible. Do not mount equipment in this zone.

Zone B: In this zone, direct lightning effects are still possible, but mounting in this zone significantly reduces the possibility of a direct strike. Mount the equipment in this zone.



Warning

Never mount equipment in Zone A. Mounting in Zone A may put equipment, structures and life at risk.

General protection requirements

To adequately protect AP installation for both ground bonding and transient voltage, surge suppression is required.

Basic requirements

Implement the following basic protection requirements:

- Install the equipment in Zone B.
- Ground the AP to the supporting structure.
- If additional surge protection is required, then install one more Surge Suppressor near the AP.
- Install the 56V-Gigabit Surge Suppressor (1000SS) within 600 mm of the point at which the power cable enters the building or equipment room.
- Ground the drop cable at the entry point of the building.
- Ensure the drop cable is not laid alongside a lightning air terminal.
- All grounding cables must be a minimum size of 10 mm² csa (8AWG), preferably 16 mm² csa (6AWG), or 25 mm² csa (4AWG).

Grounding guidelines

Implement the following requirements, when routing, fastening and connecting grounding cables:

- Ensure the grounding conductors run as short, straight, and smoothly as possible, with the minimum bends and curves.
- Do not install the grounding cables with drip loops.
- All bends must have a minimum radius of 203 mm and a minimum angle of 90° as shown in below figure. A diagonal run is preferable to a bend, even though it does not follow the contour or run parallel to the supporting structure.
- Route all bends, curves and connections towards the grounding electrode system, ground rod, or ground bar.
- Securely fasten the grounding conductors.
- Use the braided grounding conductors.
- Use the approved bonding techniques for the connection of dissimilar metals.

Figure 2: Grounding cable minimum bend radius and angle

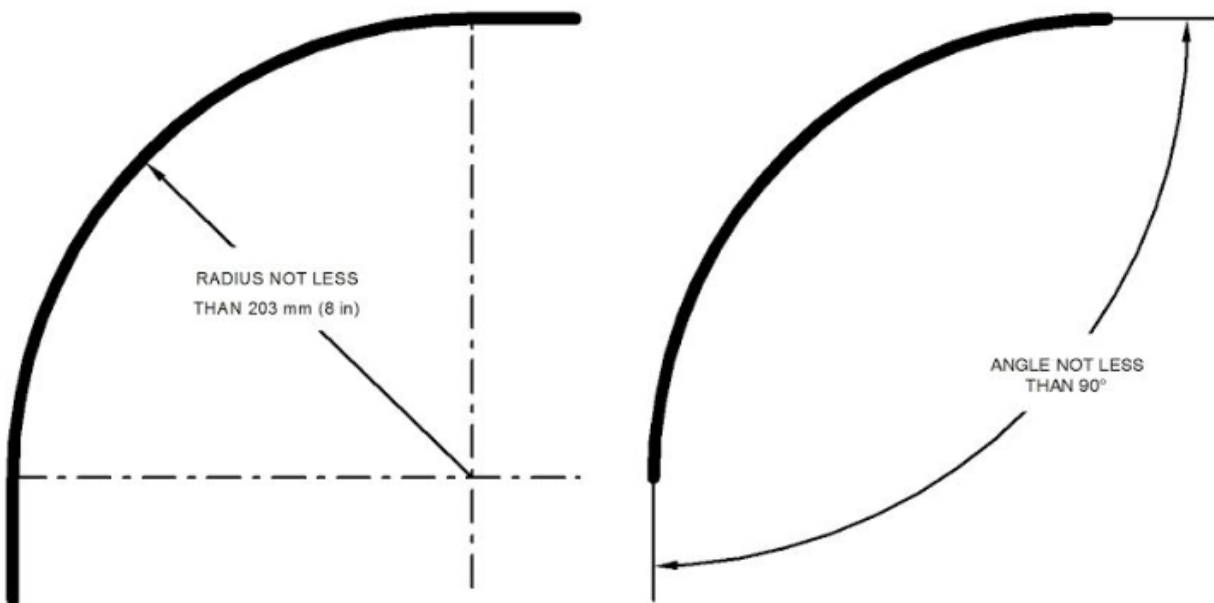

Pole or tower mount guidelines

If you need to install AP to a metal tower or pole, then in addition to the general protection requirements, follow the below requirements:

- Ensure that the position of the equipment is lower than the top of the tower or its lightning air terminal.
- Ensure that the metal tower or pole is correctly grounded.
- Install a grounding kit at the first point of contact (top), between the drop cable and the tower.
- Install a grounding kit at the bottom of the tower, near the vertical to horizontal transition point.



Note

If grounding kit is installed, ensure the grounding kit is bonded to the tower or Tower Ground Bus Bar (TGB).

Connection examples of pole or tower installations are shown in below figure.

Figure 3: Grounding and lightning protection on pole or tower

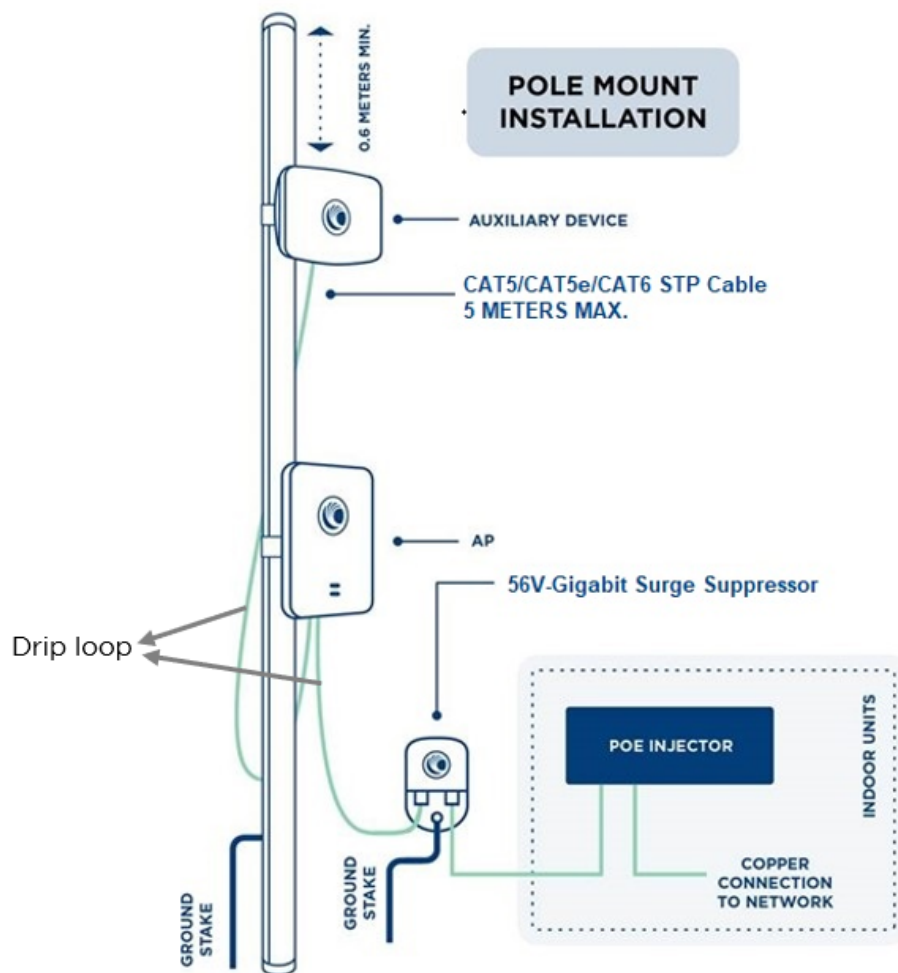

Wall mount guidelines

If you need to install AP on the wall of a building, then in addition to the general protection requirements, follow the below requirements also:

Ensure that the position of the equipment is lower than the top of the building or its lightning air terminal.

Ensure that the building is correctly grounded.

Connection examples of wall installations are shown in below figure.

Figure 4: Grounding and lightning protection on wall

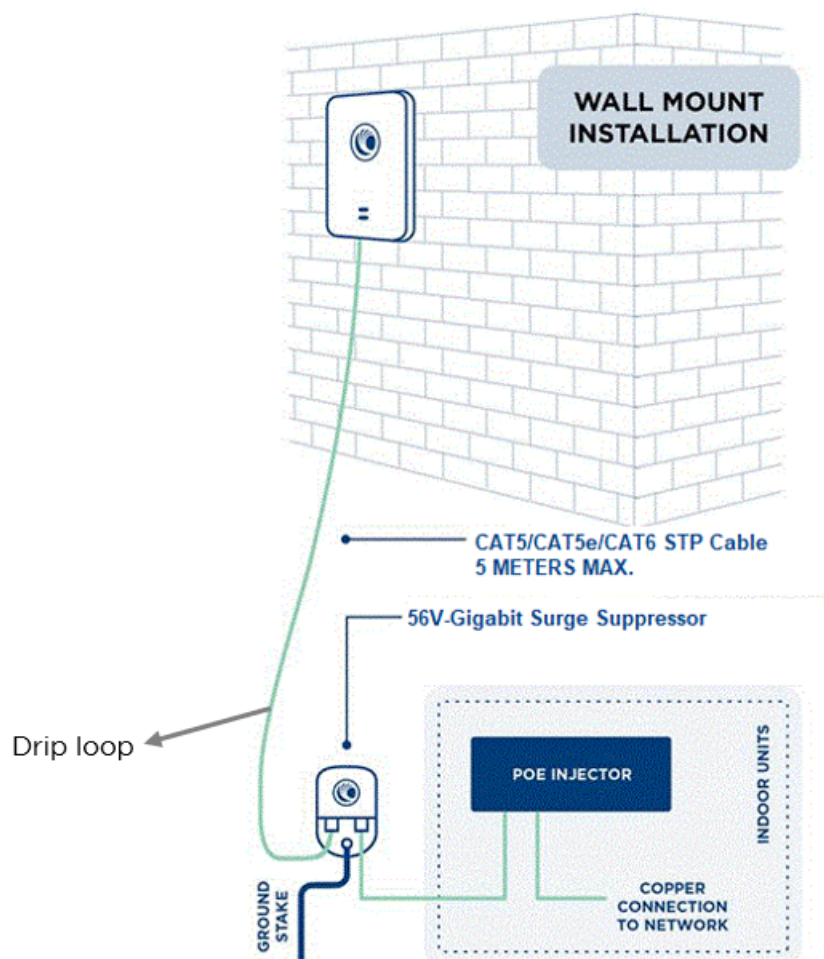

Note
There should be a drip loop immediately at the Ethernet port entrance going to the AP.

Training

The installer needs to have basic competence in radio and IP network installation. The specific requirements applicable to the cnPilot Enterprise AP must be gained by reading this User Guide and by performing sample setups at base workshop before live installations.

Power density exposure limit

This section includes the following topics:

- Calculation of power density and distance
- Calculated distances and power compliance margins

Install the radios for the 450 Platform Family of wireless solutions so as to provide and maintain the minimum separation distances from all persons.

The applicable FCC power density exposure limit for RF energy in the 2.4 and 5 GHz frequency bands is 1 mW/cm².

The applicable ISED power density exposure limit for RF energy in unlicensed bands is $0.02619 \cdot (f^{0.6834})$, where f is the lowest frequency of the supported band. For licensed bands, the power density exposure limit is $0.6455 \cdot (f^{0.5})$, where f is the lowest frequency of the supported band.

Calculation of power density and distance

The following calculation is based on the ANSI IEEE C95.1-1991 method, as that it provides a worst-case analysis. Details of the assessment to EN50383:2002 can be provided, if required.

Peak power density in the far field of a radio frequency point source is calculated as follows:

$$S = \frac{P \cdot G}{4\pi d^2}$$

P - Maximum average transmit power capability of the radio, in W

G - total Tx gain as a factor, converted from dB

S - power density (W/m²)

d - Distance from point source, in cm (Centimeters)

Table 2: Antenna details

AP	Antenna	G (For 2.4 GHz in dBi)	G (For 5 GHz in dBi)
e400	Omnidirectional	4.55	4.25
e410	Omnidirectional	4.55	4.25
e410b	Omnidirectional	4.55	5.7
e600	Omnidirectional	4.55	4.25
e430	Omnidirectional	3	4
e500	Omnidirectional	5	5
e501S	Sector	10.5	13
e502S	Sector	12.5	15.9
e700	Omnidirectional	7.5	8
e425H	Omnidirectional	4	4.29
e505	Omnidirectional	5	5
e510	Omnidirectional	8	8

For details on minimum safe distance value, please refer below table.

Calculated distances and power compliance margins

Below table displays power density and minimum safe separation distance from point source for each frequency band and antenna combination for the USA and Canada. These are conservative distances that include compliance margins.

cnPilot Enterprise AP adheres to all applicable EIRP limits for transmit power when operating in MIMO mode. Separation distances and compliance margins include compensation for both transmitters.

$$d = \sqrt{\frac{P.G}{4\pi.S}}$$

Explanation of terms used in the following tables:

- P - maximum average transmit power of the radio (Watt)
- G - total transmit gain as a factor, converted from dB
- S - power density (W/m²)
- d - minimum safe separation distance from point source (Centimeters)

Table 3: Power density and distance

Product	Regulatory Domain	Power density S (mW/cm ²)	Distance d (cm)
e400	FCC	0.4705/0.22387	20
	IC	0.54/0.975 (2.4GHz/5GHz)	20
	CE	0.196/1.555 (2.4G/5G W/ m ²)	20
e410	FCC	0.2506/0.4998	20
	IC	0.54/0.975 (2.4GHz/5GHz)	20
	CE	0.1947/5.737 (2.4G/5G W/ m ²)	20
e410b	FCC	0.233/0.725 (2.4 GHz/5GHz)	20
	IC	0.192/0.599 (2.4GHz/5GHz)	22
	CE	0.198/2.23 (2.4G/5G W/ m ²)	20
e600	FCC	0.168/0.5487	24
	IC	0.49	20
	CE	0.1375/6.257 (2.4G/5G W/ m ²)	24

Product	Regulatory Domain	Power density S (mW/cm ²)	Distance d (cm)
e430	FCC	0.139/0.164	20
	IC	0.27	20
	CE	0.1935/1.481 (2.4G/5G W/ m ²)	20
e500	FCC	0.5221/0.476	20
	IC	0.54/0.976 (2.4GHz/5GHz)	27.5
	CE	0.193/6.296 (2.4G/5G W/ m ²)	20
e501S	FCC	0.5057/0.4885	25
	IC	0.54/0.65 (2.4GHz/5GHz)	30
	CE	0.193/7.494 (2.4G/5G W/ m ²)	20
e502S	FCC	0.4665/0.4676	26
	IC	0.486	20
	CE	0.193/7.865 (2.4G/5G W/ m ²)	20
e700	FCC	0.39317/0.55028	24
	IC	0.45/0.975 (2.4G/5G)	28
	CE	0.1375/6.257 (2.4G/5G W/ m ²)	24
e425H	FCC	0.17/0.28	20
	IC	0.17/0.21 (2.4G/5G)	20
	CE	0.2/1.72 (2.4G/5G m ²)	20
e505	FCC	0.22/0.27	20
	IC	0.22/0.186	20
	CE	0.197/2.95 (2.4G/5G W/ m ²)	20
e510	FCC	0.28/0.65	22
	IC	0.22/0.186	20
	CE	0.19/7.35 (2.4G/5G W/ m ²)	20

Chapter 2: Packaging and Installation of cnPilot Enterprise Wi-Fi Access Point

This chapter describes the following topics:

- [Unpacking cnPilot Enterprise Wi-Fi Access Point](#)
- [Package contents](#)
- [Mounting the device](#)

Unpacking cnPilot Enterprise Wi-Fi Access Point

After you purchase a cnPilot Enterprise Wi-Fi Access Point (AP), unpack the AP and check the package contents.

1. Open the AP package, and then carefully remove the contents.
2. Verify that all items listed in Package contents below are included in the package. Check each item for damage. If any item is damaged or missing, notify your authorized cnPilot sales representative.

Package contents

A complete cnPilot Enterprise Wi-Fi AP package contains all the items listed below:

1. cnPilot Enterprise Wi-Fi AP
2. Quick Start Guide (QSG)
 - a. Specifications
 - b. Safety Notice
 - c. Compliance
3. Hardware Accessories (Based on SKU/Model)
 - a. Ethernet Cables
 - b. Power Adapters
 - c. Mounting Kits
 - d. Rubber Feet

Mounting the device

This section includes the following topics:

- [Mounting e400/e410/e600](#)
- [Mounting e410b](#)
- [Mounting e500](#)
- [Mounting e501S/e502S](#)
- [Mounting e700](#)
- [Mounting e430/e425H](#)
- [Mounting e505/e510](#)

cnPilot Enterprise Wi-Fi APs feature an attractive design with flexible mounting options that allows the APs to smoothly blend into any business environment. cnPilot Enterprise Wi-Fi APs are mounted in the following methods:

- Wall Mount
- Ceiling Mount
- T-bar Mount
- Pole Mount
- Gang Mount
- Table Mount

Below table provides an overview of the type of mountings each cnPilot Enterprise Wi-Fi AP supports.

Table 4: Types of mounting the device

Access Point	Wall Mount	Ceiling Mount	T-bar Mount	Pole Mount	Gang Mount	Table Mount
e400	✓	✓				
e410	✓	✓	✓			
e410b	✓	✓	✓			
e600	✓	✓	✓			
e430	✓				✓	✓
e500	✓			✓		
e501S	✓			✓		
e502S	✓			✓		
e700	✓			✓		
e425H	✓				✓	
e505	✓			✓		
e510	✓			✓		

Mounting e400/e410/e600

Ceiling mount

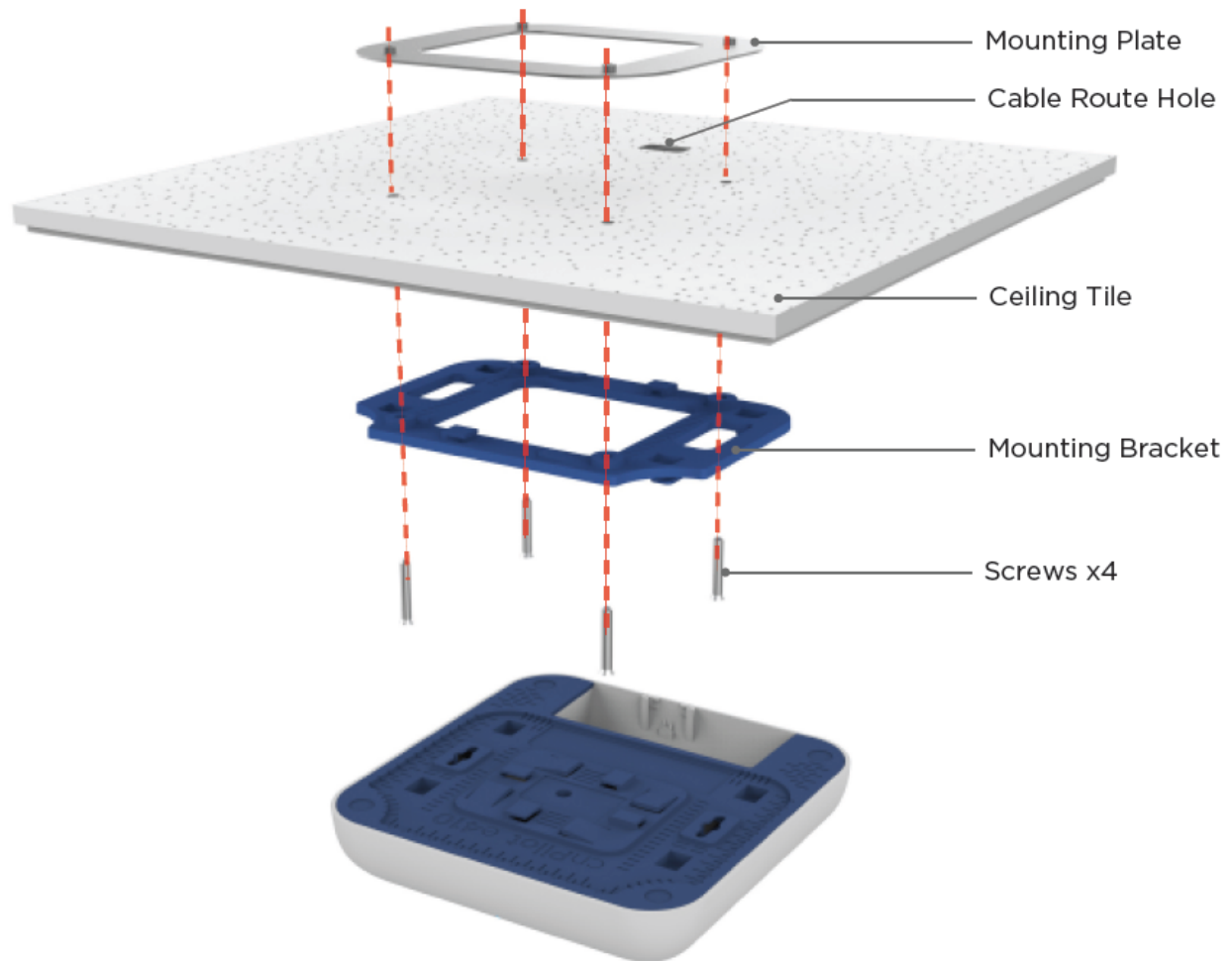

1. Determine where e400 needs to be mounted and remove the ceiling tile.
2. Using the hole template, mark the hole locations.
3. Drill the holes for the 4 mounting screws using a 5mm (3/6") diameter drill bit.
4. Drill the RJ45 cable hole using a 15 mm (5/8") diameter bit.
5. Hold the mounting plate on the top side of the ceiling tile and screw it on the mounting bracket.
6. Run the RJ45 cable through the 15mm hole and remount the ceiling tile.
7. Attach the RJ45 cable to e400.
8. Slide the e400 into the mounting bracket.

Wall Mounting

The e410 mounts to any wall by using two screws with corresponding wall anchors. The ceiling mount bracket can be used as a template to align the screws with the unit.

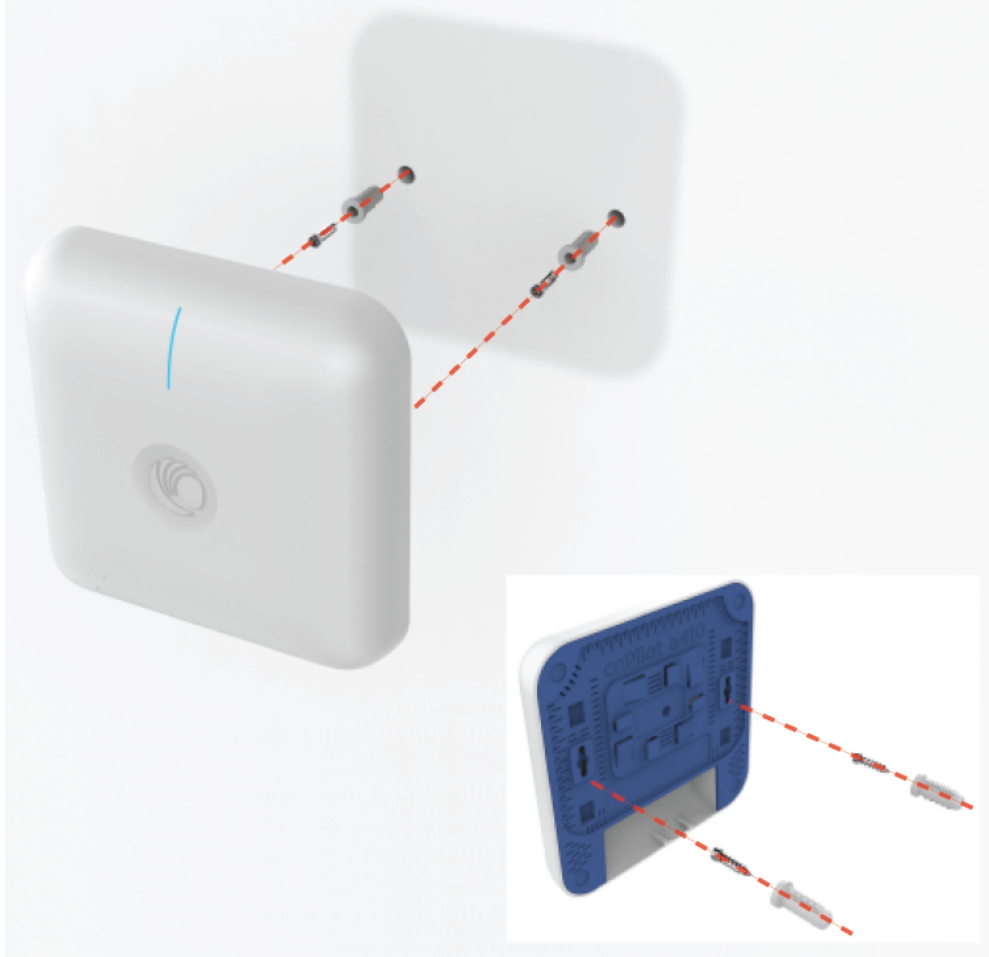

T-Bar Mounting

38mm T-Bar:

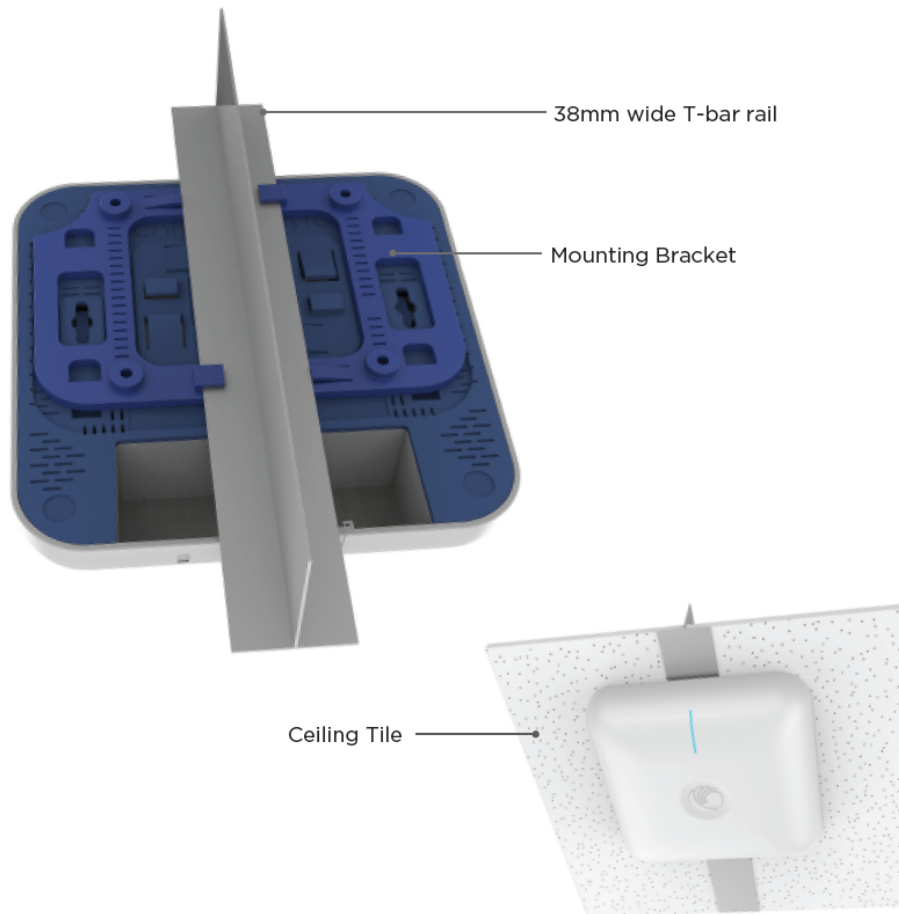

The e410 can be secured to a 38mm ceiling T-bar rail by using the ceiling mount bracket.

24mm T-Bar

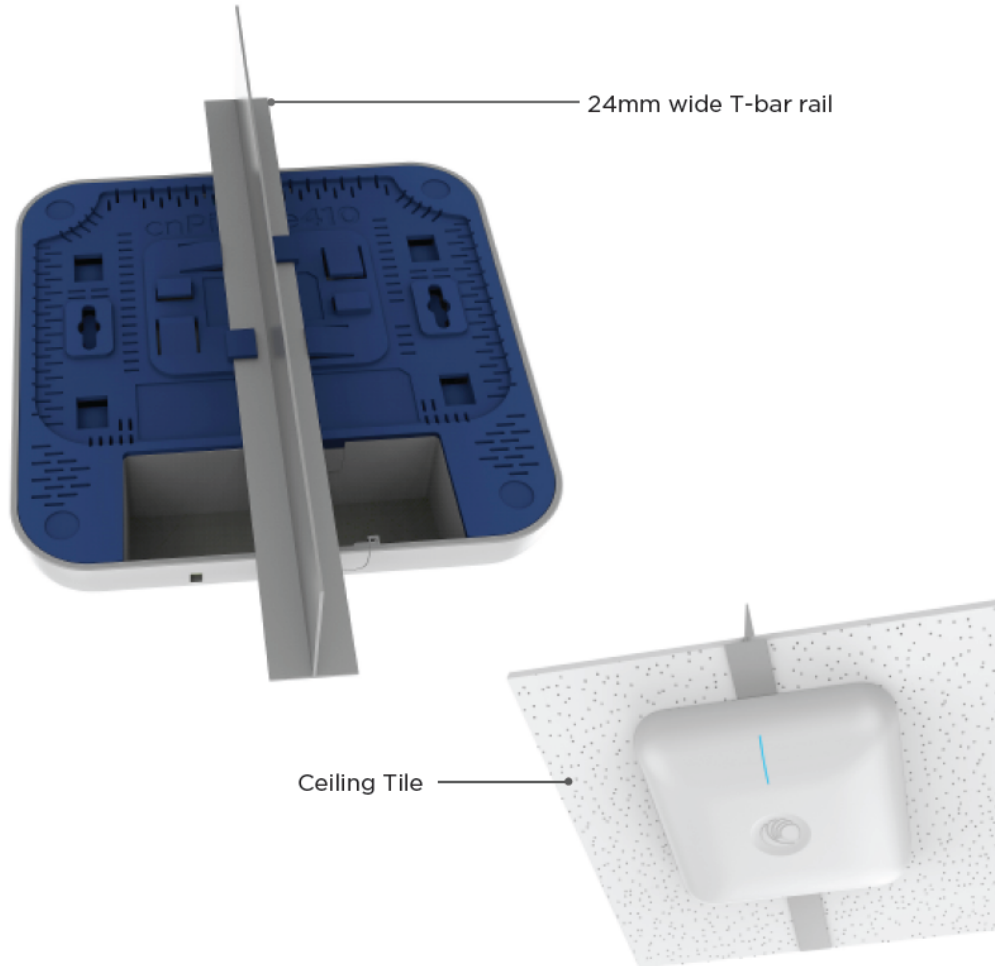

The e410 can be mounted to a 24mm width T-bar rail using the clips built into the underside of the unit.

14mm T-Bar

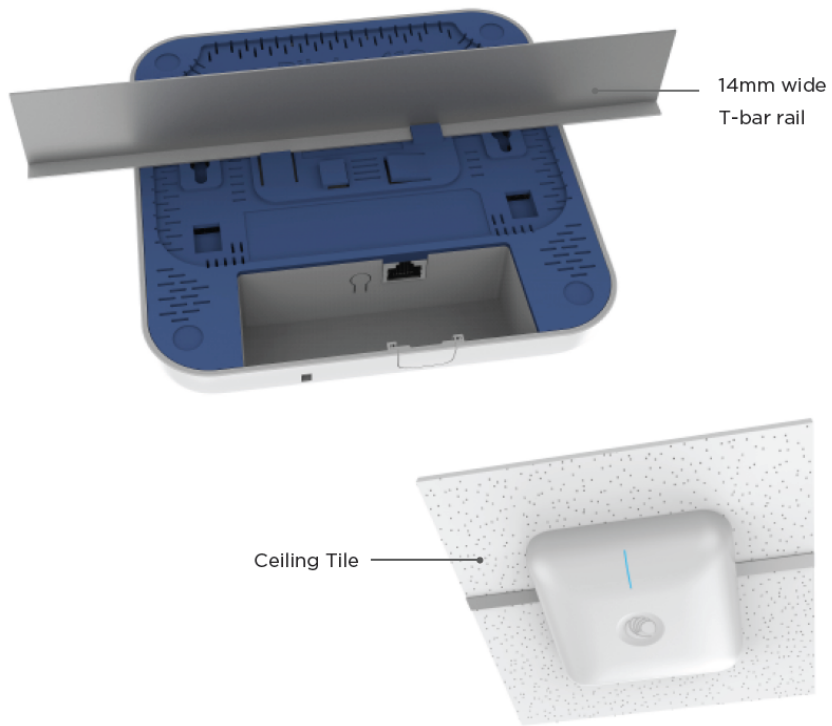

The e410 can be mounted to a 14mm width T-bar rail using the clips built into the underside of the unit.

Mounting e410b

Ceiling Mount:

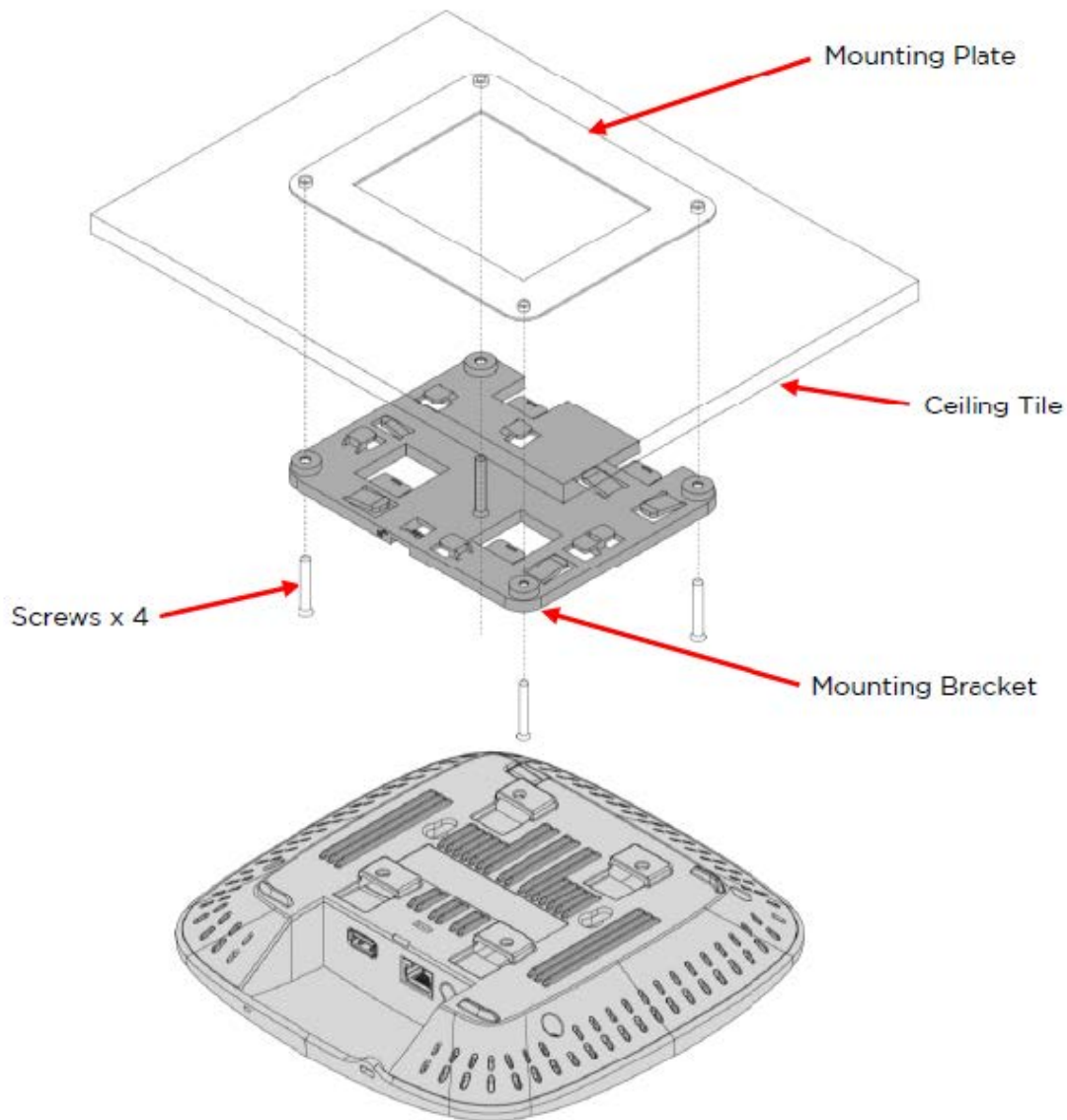

1. Determine where e410b needs to be mounted and remove the ceiling tile.
2. Using the hole template, mark the hole locations.
3. Drill the holes for the 4 mounting screws using a 5mm (3/6") diameter drill bit.
4. Drill the RJ45 cable hole using a 15 mm (5/8") diameter bit.
5. Hold the mounting plate on the top side of the ceiling tile and screw it on the mounting bracket.
6. Run the RJ45 cable/cables through the 15mm hole and remount the ceiling tile.

7. Attach the RJ45 cable/cables to e410b.
8. Slide e410b into the mounting bracket.

Wall Mounting:

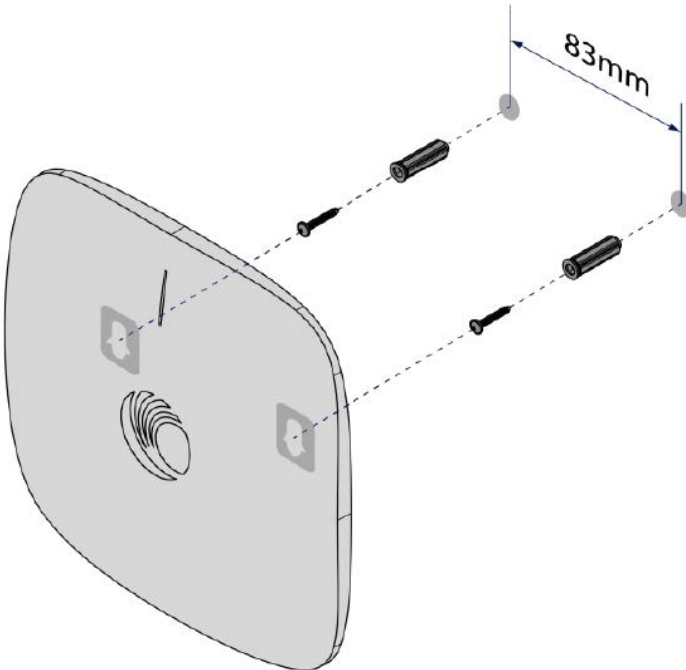

The e410b mounts to any wall by using two screws with corresponding wall anchors. The ceiling mount bracket can be used as a template to align the screws with the unit.

T-bar Mounting

38mm T-Bar:

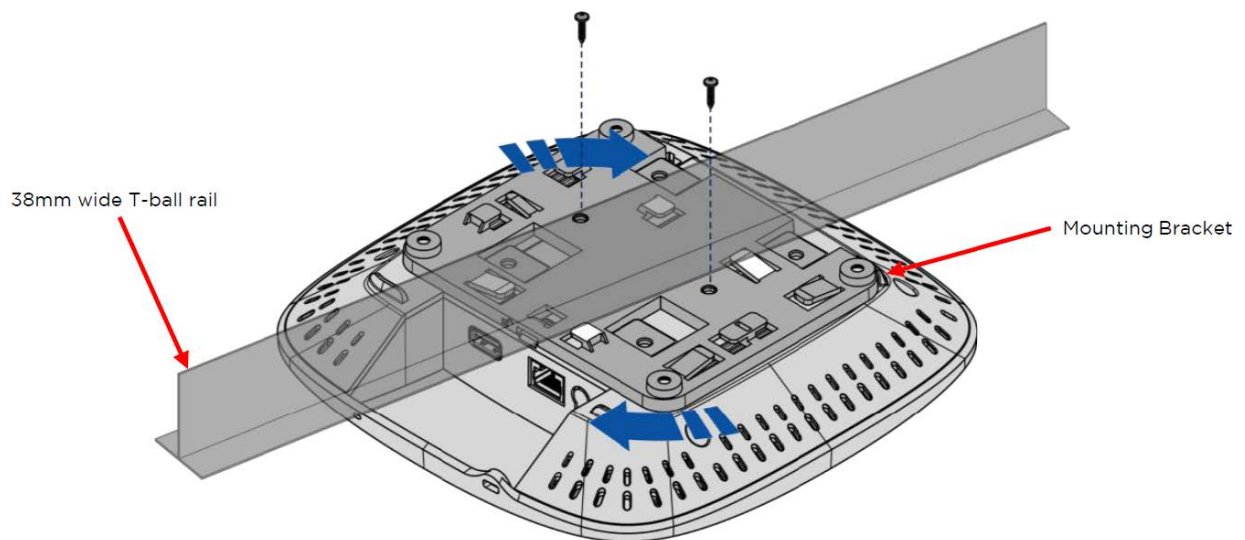

The e410b can be secured to a 38mm ceiling T-bar rail by using the ceiling mount bracket (The “A” marking on the bracket is to be used for this width T-bar rail).

24mm T-Bar:

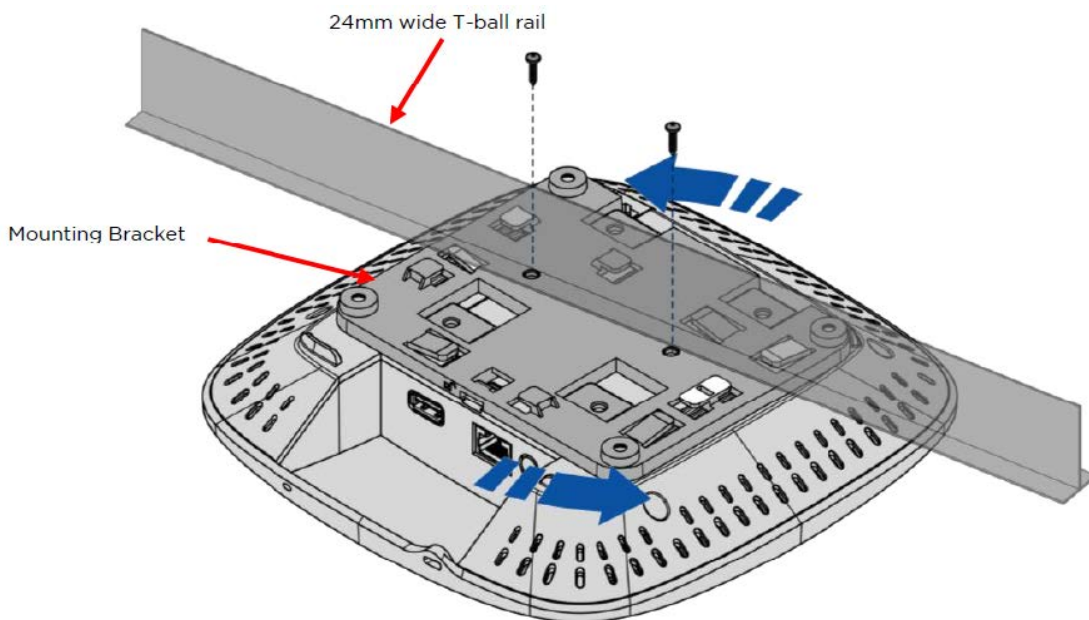

The e410b can be mounted to a 24mm width T-bar rail using the clips built into the underside of the unit (The “B” marking on the bracket is to be used for this width T-bar rail).

14mm T-Bar:

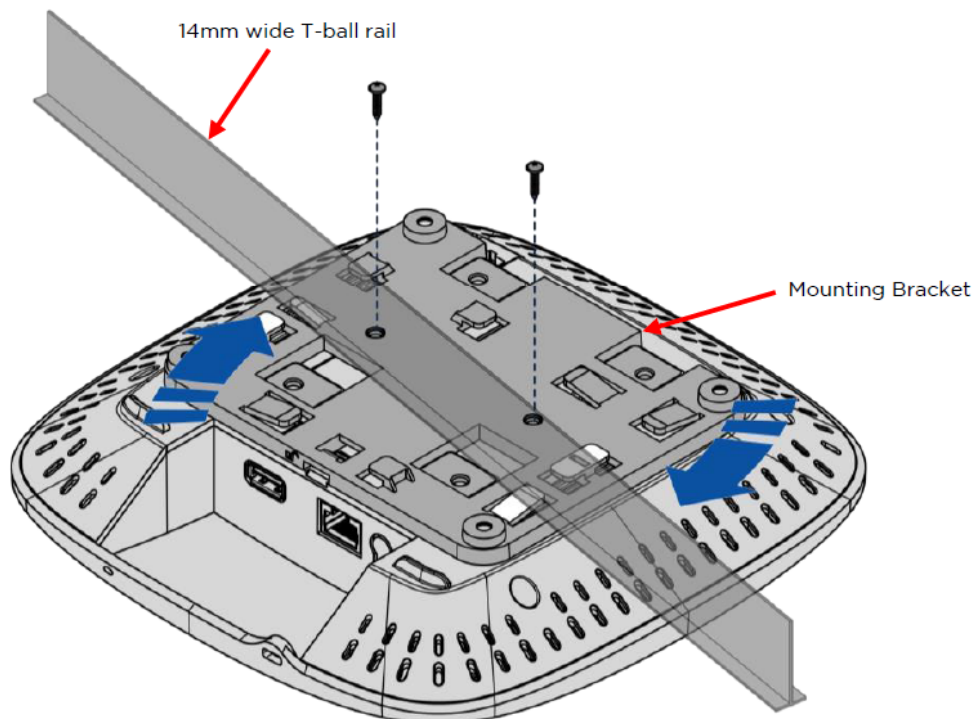

The e410b can be mounted to a 14mm width T-bar rail using the clips built into the underside of the unit (The “C” marking on the bracket is to be used for this width T-bar rail).

Mounting e500

Pole mount

1. Insert hose clamps through pole mounting bracket and clamp to pole by applying 3.0 Nm torque.



2. Align the radio chassis with the guide rails of pole mounting bracket and slide it downwards until it clicks into place.



3. Insert RJ45 cable into cable gland, and connect the cable to the device



4. Lock cable gland to radio housing with 1.5 Nm to 2 Nm torque.

Wall Mounting (w/o bracket)

1. Drill 4 holes of $\text{Ø}6\text{mm}$ ($\text{Ø}0.25''$ Inch) on wall.
2. Press fit plastic anchor and assembly fastener.
3. Leave 5mm to 6mm gap between wall and fastener head.

4. Use the four mounting slots given on the back of the radio to mount to the wall.

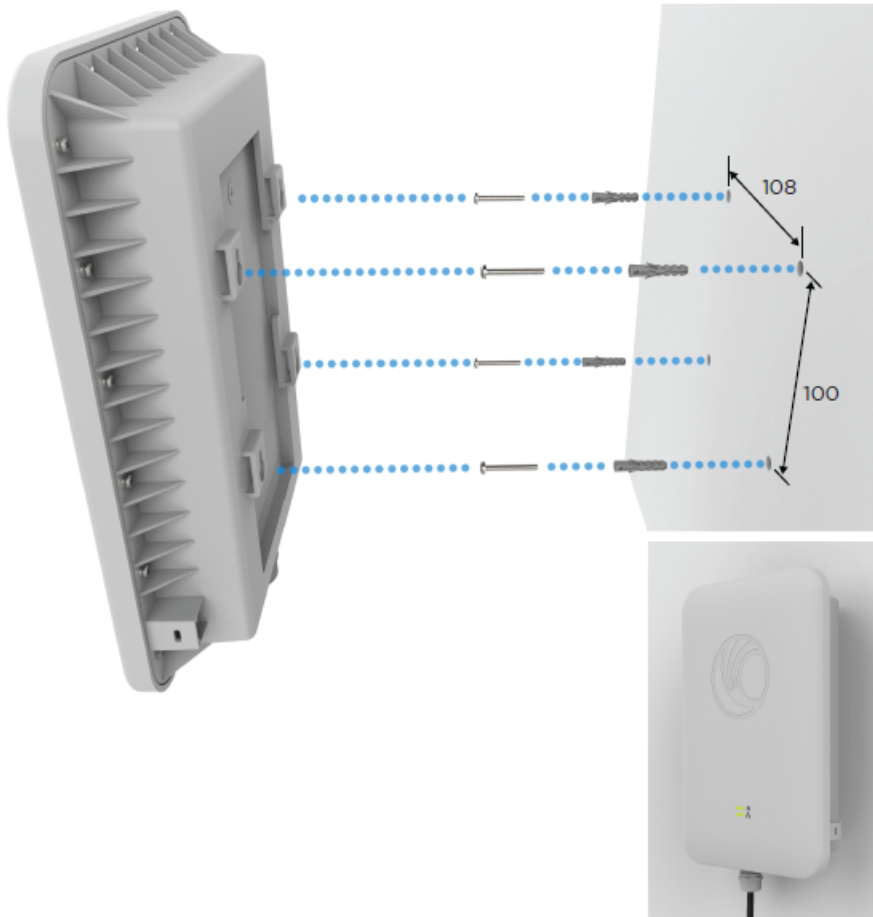

Wall Mounting (with bracket)

1. Insert the wall anchors into the wall using the mounting bracket as a template and insert the screws.

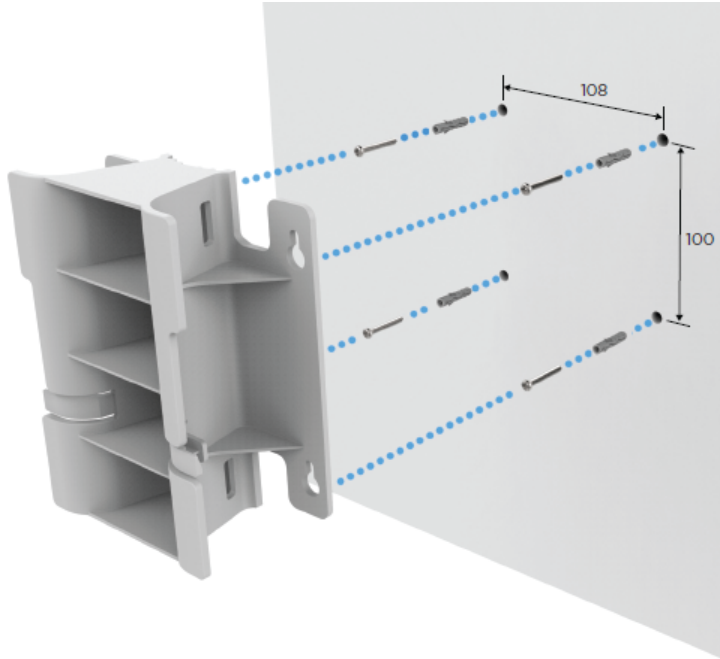

2. Drill 4 holes of $\text{Ø}6\text{mm}$ ($\text{Ø}0.25''$ Inch) on wall.
3. Press fit plastic anchor and assembly fastener.
4. Leave 5mm to 6mm gap between wall and fastener head.
5. Attach the mounting bracket to the screws and then attach the device into the mounting bracket.



Mounting e501S/e502S

Pole mount

1. Assemble the radio holder to the pole mounting bracket and secure it with M8 nuts by applying 3.0 Nm torque.



2. Insert hose clamps through pole mounting bracket and clamp to pole by applying 3.0 Nm torque.



3. Align the radio chassis with the guide rails of radio holder and slide it downwards until it clicks into place.



4. Insert RJ45 to radio housing and the lock cable gland to radio housing with 1.5Nm to 2Nm torque.

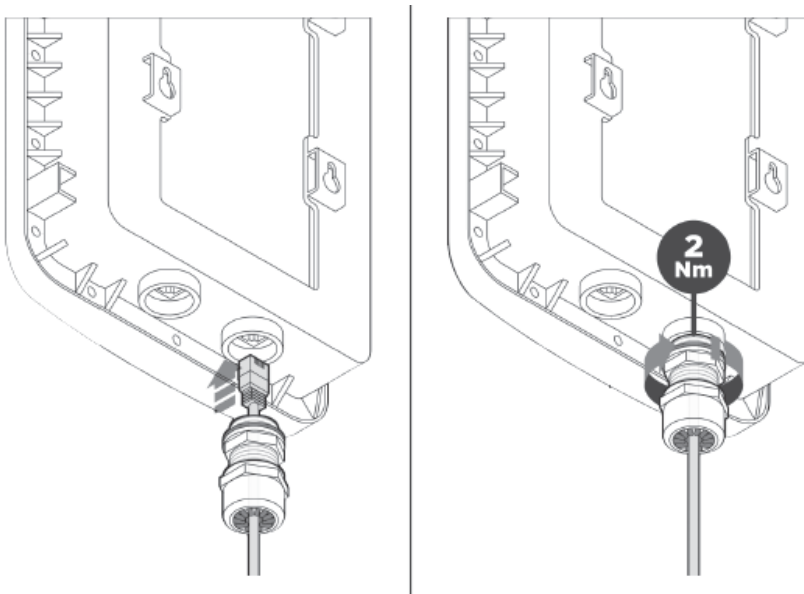

Wall Mounting

1. Drill 4 holes of $\text{Ø}6\text{mm}$ ($\text{Ø}0.25''$ Inch) on wall.
2. Press fit plastic anchor and assembly fastener.

3. Leave 5mm to 6mm gap between wall and fastener head.
4. Use the four mounting slots given on the back of the radio to mount to the wall.

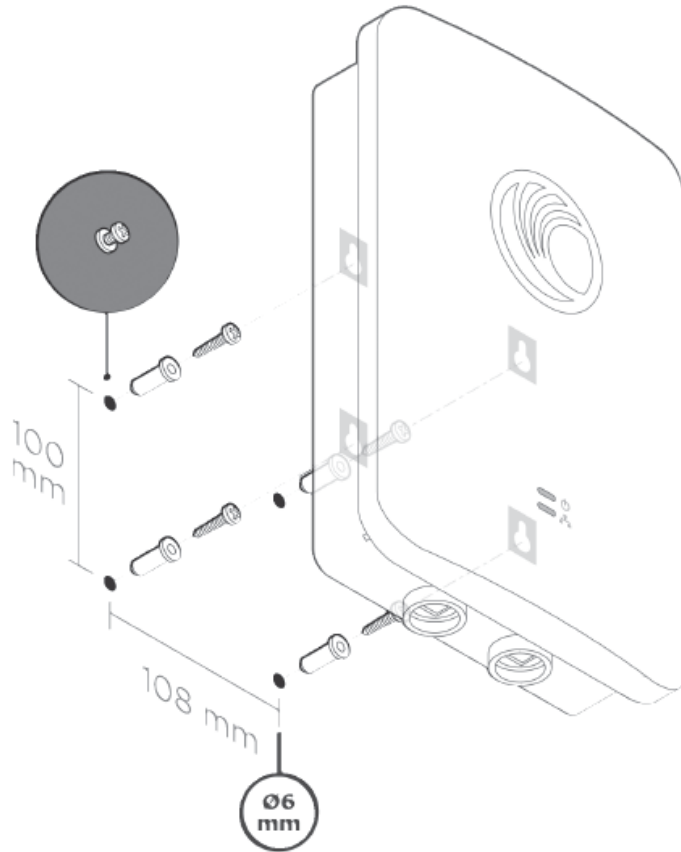

Mounting e700

The e700 units are mounted by using one of the following mounting techniques:

- Pole mount, or
- Wall mounting

Pole mount

1. Assemble the device to the pole mounting bracket with corresponding screws by applying 3.0 Nm torque.

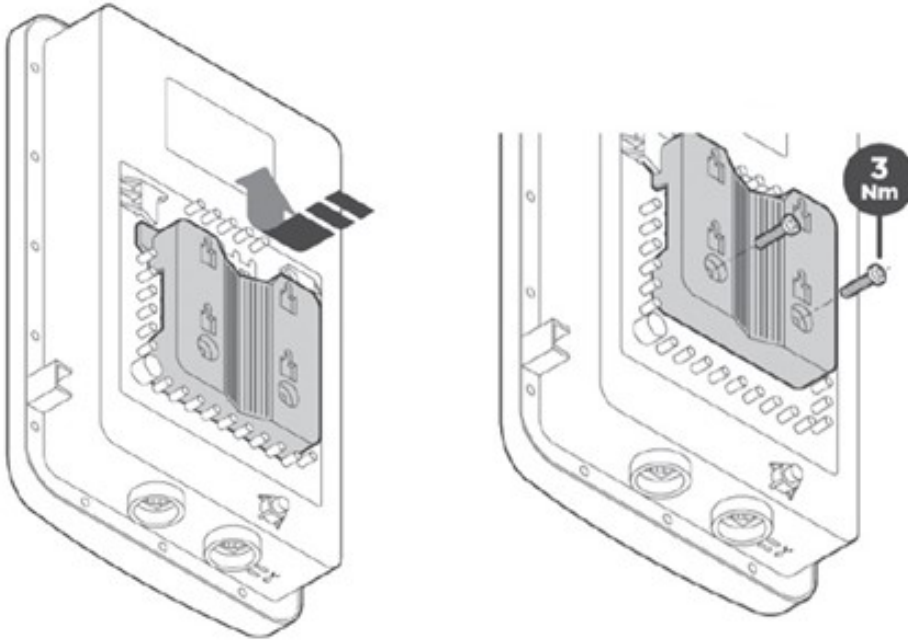

2. Insert hose clamps through pole mounting bracket and clamp to pole by applying 3.0 Nm torque.

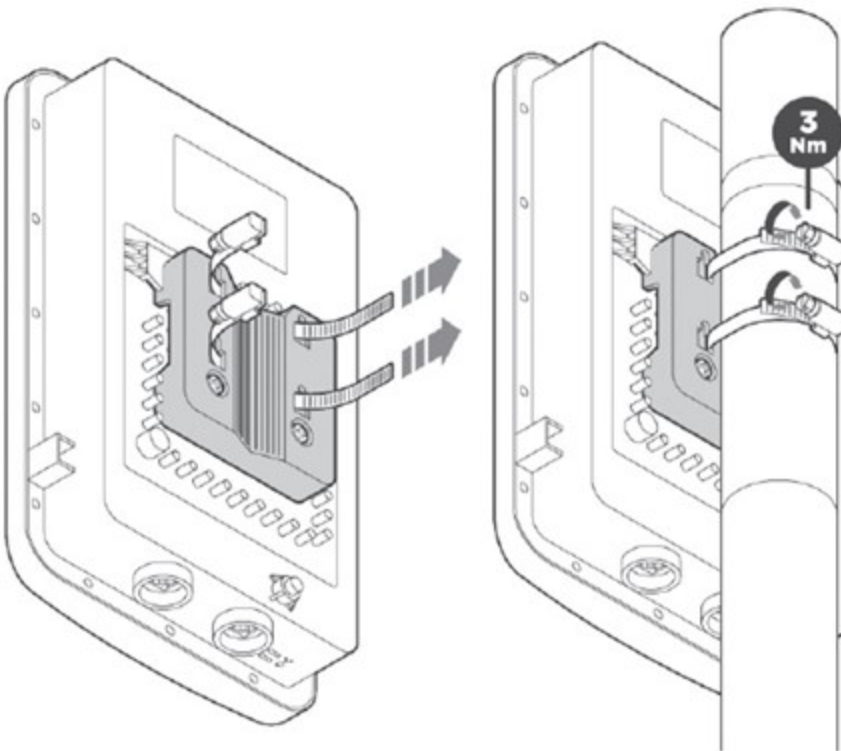

3. Insert RJ45 to radio housing and the lock cable gland to radio housing with 2Nm torque.

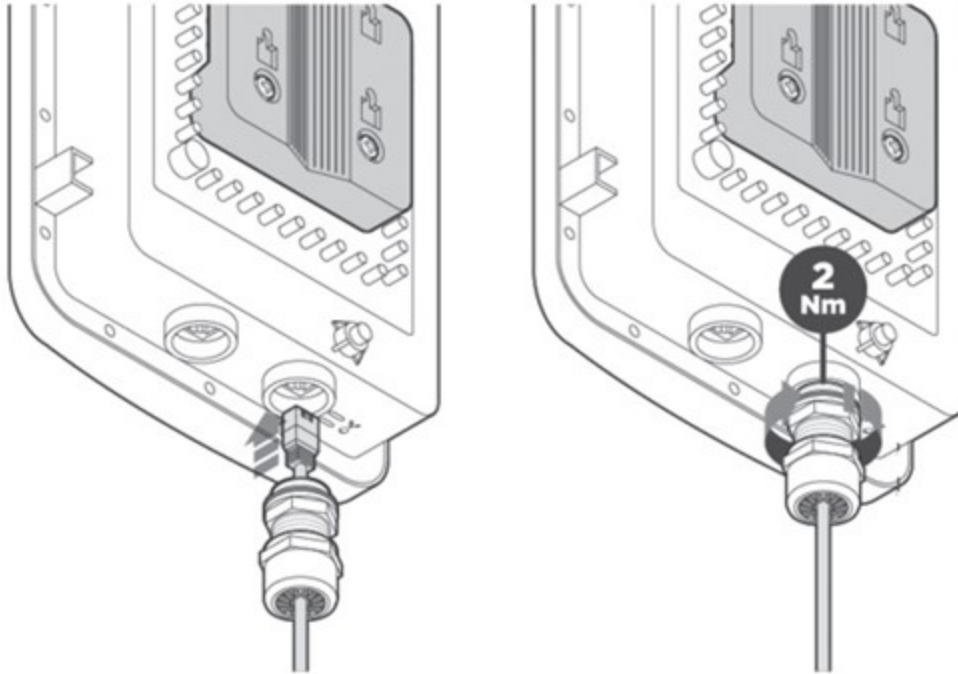

Wall Mounting

1. Drill 4 holes of $\text{Ø}4.7\text{mm}$ ($\text{Ø}0.18''$ Inch) on wall.
2. Press fit plastic anchor and assembly fastener.
3. Leave 5mm to 6mm gap between wall and fastener head.

4. Use the four mounting slots given on the back of the radio to mount to the wall.

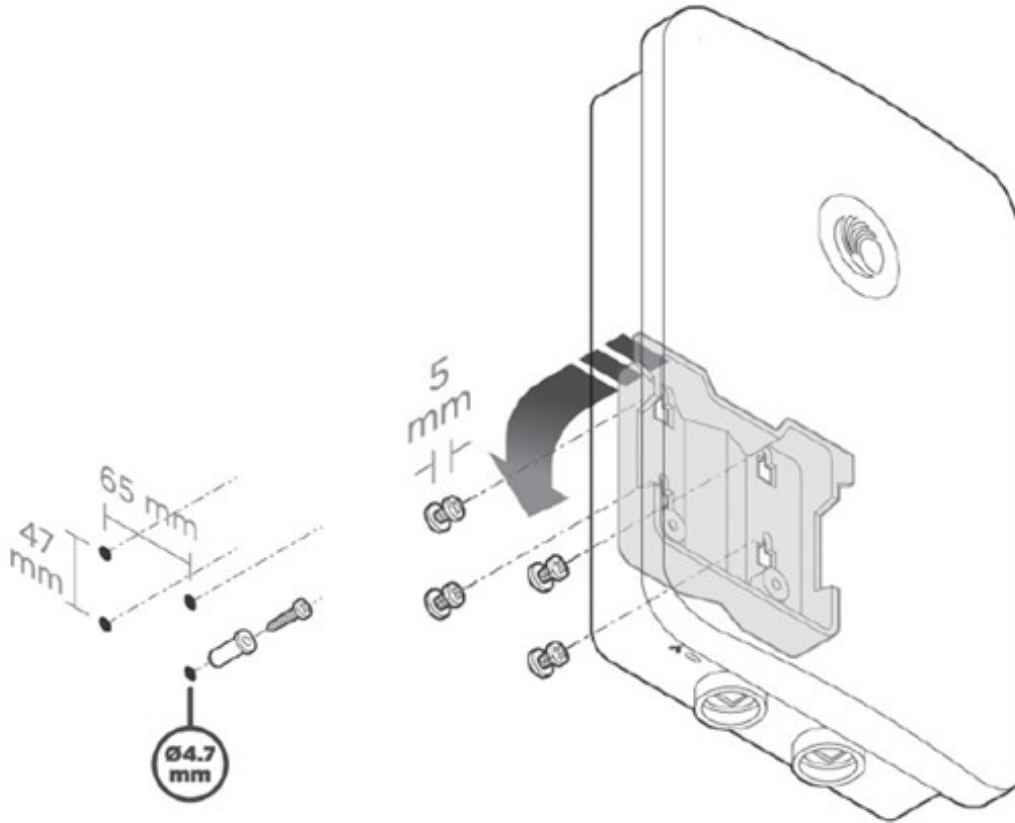

Mounting e430/e425H

Single Gang Mounting

1. Remove single-gang box cover.
2. Place Cambium single-gang wall bracket on the gang box and secure with at least 2 screws.

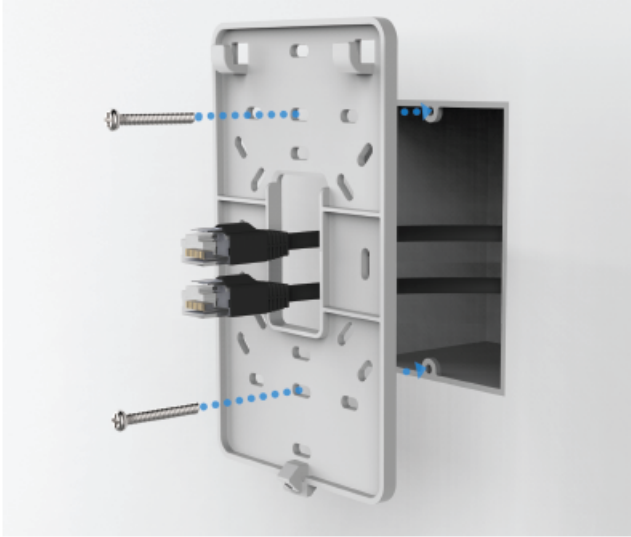

3. Connect Ethernet cable to the upper RJ-45 port labelled Eth1/PoE at the rear side of e430 to provide connectivity. Use the other RJ-45 port labelled Pass-Through for any additional cable that might need to pass through e430.
4. Align the two slots at rear side of the e430/e425H with two hooks on the bracket.

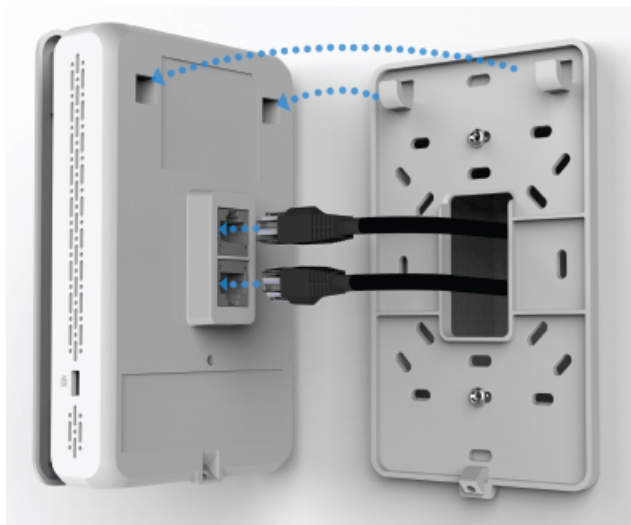

5. Secure e430/e425H to the bracket with a screw at the bottom edge of e430/e425H using standard Torx security screw or standard Philips head screw.



Dual Gang Mounting

1. Remove dual-gang box cover.



2. Place Cambium dual-gang wall bracket on the gang box and secure with at least two screws.



3. Slide the plastic cover over the exposed portion next to the mounted e430/e425H.
4. Connect Ethernet cable to the upper RJ-45 port labelled Eth1/PoE at the rear side of e430 to provide connectivity. Use the other RJ-45 port labelled Pass-thru for any additional cable that might need to pass through e430.

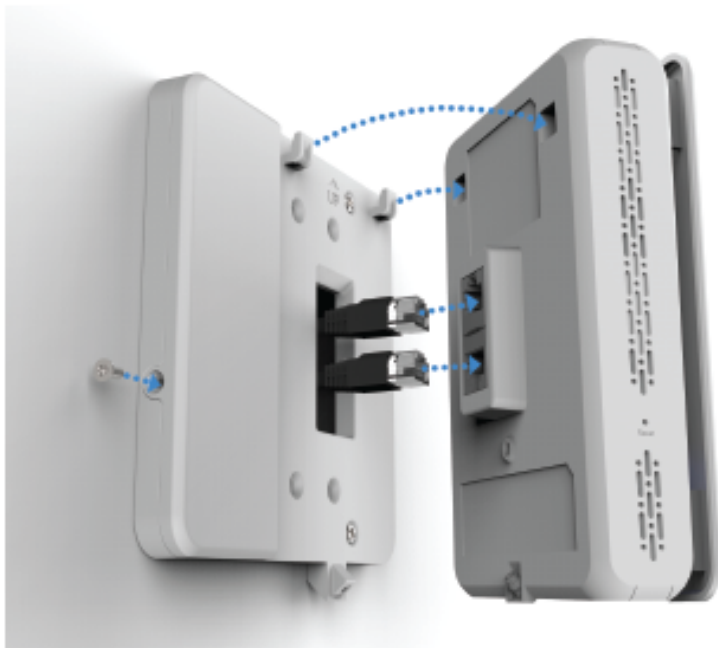

5. Align the two slots at rear side of e430/e425H with two hooks on the bracket.
6. Secure e430/e425H to the bracket with a screw at the bottom edge of e430/e425H using standard Philips head or Torx security screwdriver.

Wall Mounting

1. Choose location on the wall to mount the bracket using the four mounting screws and anchors (if needed).

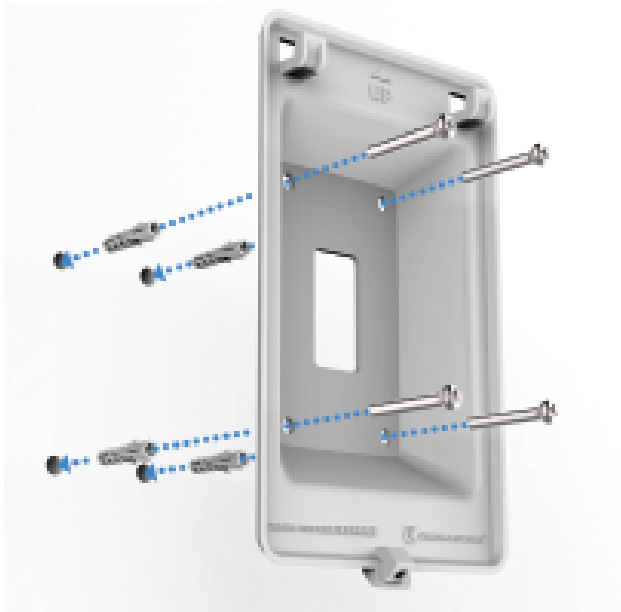

2. Connect the short Ethernet jumper cable between the two RJ-45 connections on the rear side of e430.
3. Mount e430/e425H into the Generic Wall bracket by aligning the hooks.

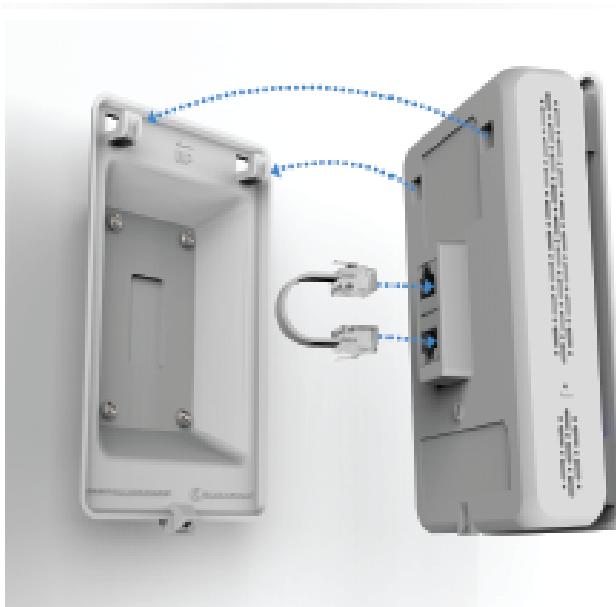

4. Secure e430/e425H to the bracket using Torx (or standard) screw on the lower edge of e430/e425H.
5. Power e430 either with a 48Vdc/1A power adapter or using the PASS-THRU port at the bottom edge of the device using Ethernet power.



Mounting e505/e510

Pole Mount

Insert hose clamps through pole mounting bracket and clamp to pole by applying 3.0 Nm torque.

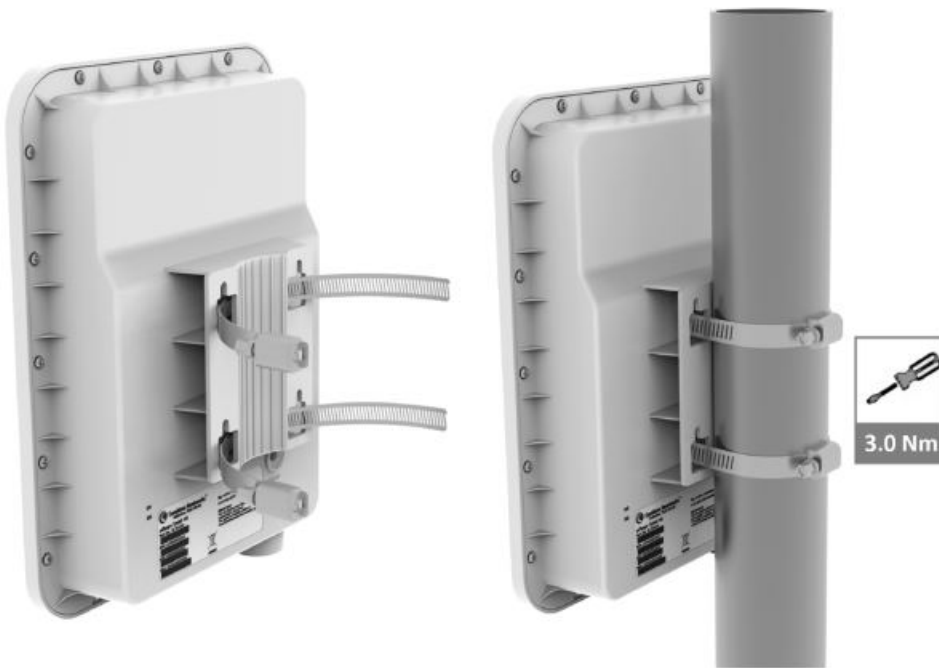

Wall Mounting

1. Drill 4 holes of $\text{Ø}6\text{mm}$ ($\text{Ø}0.25''$ Inch) on wall.
2. Press fit plastic anchor and assembly fastener.
3. Leave 5mm to 6mm gap between wall and fastener head.
4. Use the four mounting slots given on the back of the radio to mount to the wall.

